

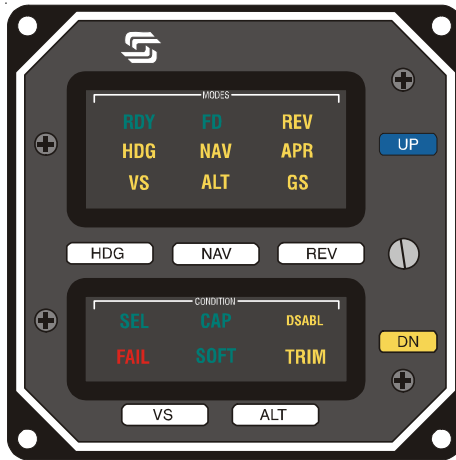

# S-TEC

## System 60-2 Autopilot Pilot's Operating Handbook



S-TEC  
One S-TEC Way  
Municipal Airport  
Mineral Wells  
TX 76067-9236  
USA

Tel: +1(940) 325 9406  
Toll-free: +1(800) 872 7832  
Fax: +1 (940) 325 3904

[www.s-tec.com](http://www.s-tec.com)  
[www.meggitt.com](http://www.meggitt.com)

# MEGGITT



Page Intentionally Blank

## Table of Contents

<u>Section</u>	<u>Page</u>
1.0 Introduction.....	1-3
2.0 Block Diagram.....	2-3
3.0 Autopilot Overview.....	3-3
3.1 System 60-2 Programmer/Annunciator.....	3-3
3.2 Roll Modes of Operation.....	3-4
3.2.1 Heading (HDG).....	3-4
3.2.2 Navigation (NAV).....	3-4
3.2.3 Reverse (REV).....	3-5
3.3 Pitch Modes of Operation.....	3-5
3.3.1 Vertical Speed (VS).....	3-5
3.3.2 Altitude (ALT).....	3-6
3.3.3 UP.....	3-6
3.3.4 Down (DN).....	3-6
4.0 Procedures.....	4-3
4.1 Pre-Flight Procedures.....	4-3
4.1.1 Roll Axis.....	4-3
4.1.2 Pitch/Altitude and Vertical Speed.....	4-4
4.1.3 Autotrim.....	4-5
4.2 Normal Operating Procedures.....	4-6
4.2.1 Roll Axis Modes.....	4-6
4.2.1.1 Heading.....	4-6
4.2.1.2 VOR Intercept and Tracking (DG).....	4-6
4.2.1.3 VOR Approach (DG).....	4-8
4.2.1.4 Localizer Intercept and Tracking (DG).....	4-9
4.2.1.5 VOR/Localizer Intercept and Tracking (HSI)....	4-14
4.2.1.6 Dual Mode Intercept.....	4-15

## Table of Contents

<u>Section</u>	<u>Page</u>
4.2.2 Pitch Axis Modes.....	4-20
4.2.2.1 Vertical Speed (VS).....	4-20
4.2.2.2 Altitude Hold (ALT).....	4-21
4.2.2.3 Intercepting and Coupling the Glideslope.....	4-21
4.2.2.4 Manual Arm/Automatic Capture.....	4-22
4.2.2.5 Elevator Trim Indicator.....	4-25
4.2.2.6 Optional Autotrim.....	4-26
4.3 Flight Director Operations (Optional).....	4-26
4.3.1 Single Cue .....	4-26
4.3.2 Two Cue .....	4-27
4.4 Yaw Damper/Rudder Trim System (Optional).....	4-27
5.0 Appendixes.....	5-3
6.0 Glossary.....	6-3

## List of Figures

<b><u>Figure</u></b>	<b><u>Page</u></b>
2-1 System 60-2 Block Diagram.....	2-3
3-1 System 60-2 Programmer/Annunciator.....	3-3
4-1 Directional Gyro.....	4-6
4-2 VOR/LOC/GPS.....	4-8
4-3 Straight-In Localizer Approach and Tracking (DG).....	4-10
4-4 Procedure Turn Localizer Approach and Tracking (DG).....	4-11
4-5 Back Course Straight-In Approach (DG).....	4-12
4-6 Back Course Procedure Turn (DG).....	4-13
4-7 Horizontal Situation Indicator (HSI).....	4-14
4-8 Straight-In Localizer Approach and Tracking (Optional HSI).....	4-16
4-9 Procedure Turn Localizer Approach and Tracking (Optional HSI).....	4-17
4-10 Back Course Straight-In Approach (Optional HSI).....	4-18
4-11 Back Course Procedure Turn (Optional HSI).....	4-19
4-12 Glideslope Intercept and Track.....	4-23
4-13 Procedure Turn for Glideslope Approach.....	4-24

Page Intentionally Blank

# **SECTION 1 INTRODUCTION**

Page Intentionally Blank

## 1.0 Introduction

The primary purpose of the System 60-2 **Pilot Operating Handbook (POH)** is to provide pilots with step-by-step Functional Preflight and In-Flight Operating Procedures for the installed system.

### **Notice**

This handbook must be in conjunction with the Federal Aviation Administration (FAA) approved Aircraft Flight Manual (AFM) or Aircraft Flight Manual Supplement (AFMS). Refer to the applicable AFM or AFMS for specific information, aircraft emergency procedures, and return of aircraft to service.

If the autopilot is to be used during Instrument Flight Rules (IFR) operations, we recommend that you develop a thorough understanding of the autopilot system, its functions, and characteristics in Visual Meteorological Conditions (VMC). Accomplish this before undertaking an IFR flight.

Page Intentionally Blank

# **SECTION 2 BLOCK DIAGRAM**

Page Intentionally Blank

## 2.0 Block Diagram

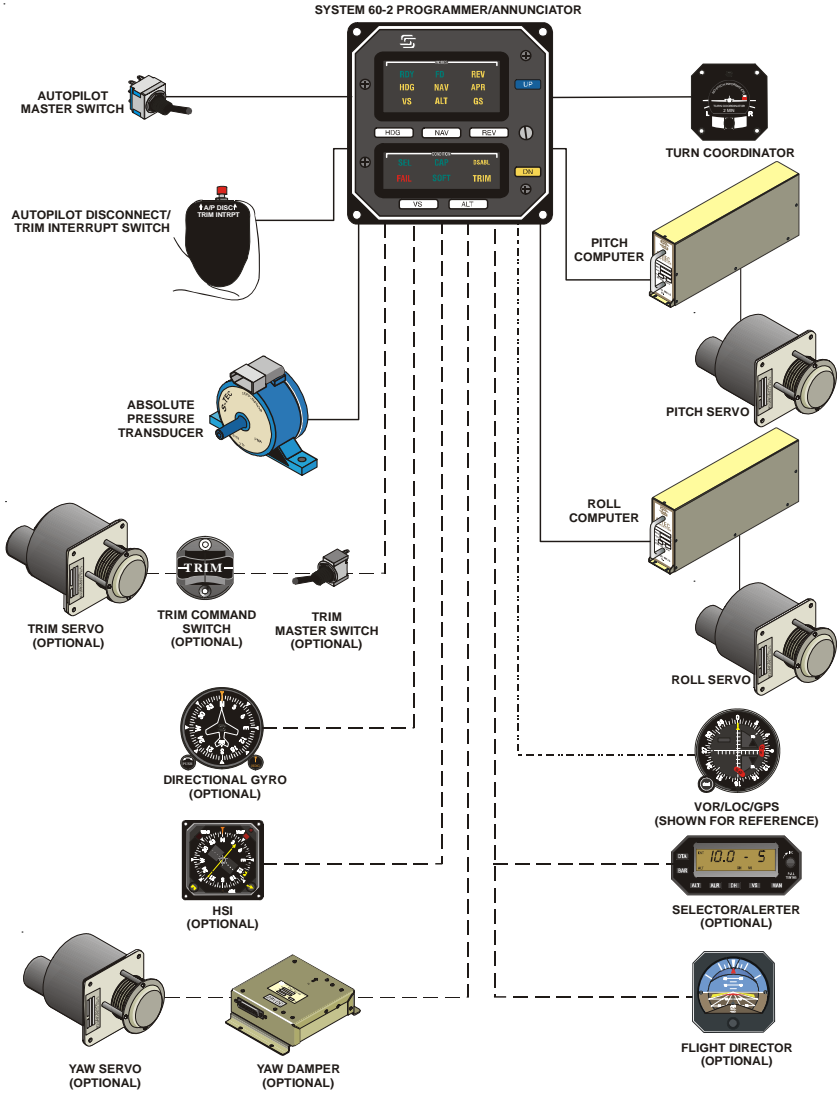

**Fig. 2-1. System 60-2 Block Diagram**

Page Intentionally Blank

# **SECTION 3 AUTOPILOT OVERVIEW**

Page Intentionally Blank

### 3.0 Autopilot Overview

#### 3.1 System 60-2 Programmer/Annunciator

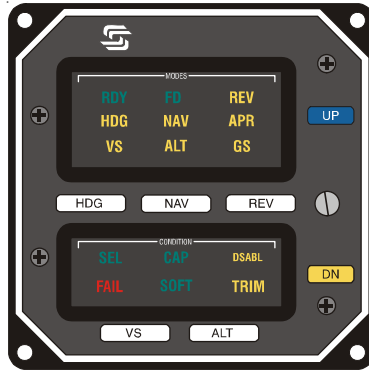

**Fig. 3-1. System 60-2 Programmer/Annunciator**

The System 60-2 Programmer/Annunciator is a rate based autopilot that controls the roll and pitch axis of the aircraft. The autopilot's main function is to convert pilot commands to logic signals for both the roll and pitch computers. As the pilot enters the desired mode by pressing the mode selector switch, the computer acknowledges the selection by illuminating that annunciator.

The Roll Computer receives signal inputs from the turn coordinator, Directional Gyro or optional Horizontal Situation Indicator (HSI), Very High Frequency Omnidirectional Radio Range (VOR) / Localizer (LOC), Long Range Navigation (LORAN) and the Global Positioning System (GPS) navigation receivers. It then computes roll servo commands for stabilization, turns, radio intercepts, and tracking.

The Pitch Computer receives signal inputs from the altitude pressure transducer, internal accelerometer, glideslope deviation indicator, and off warning flag contained in the glideslope receiver. The pitch system provides vertical speed control and altitude hold, as well as automatic/manual glideslope capture.

Vertical speed reference is provided by the barometric pressure transducer, while automatic and manual pitch trim sensing is provided by the pitch servo. Drive for the elevator trim servo is provided by the pitch computer. All modes use the transducer signal for a VS or ALT reference.

### 3.2 Roll Modes of Operation

#### 3.2.1 Heading (HDG)

The HDG mode provides heading preselect and turns through the use of the heading bug on the Directional Gyro (DG) or optional Horizontal Situation Indicator (HSI).

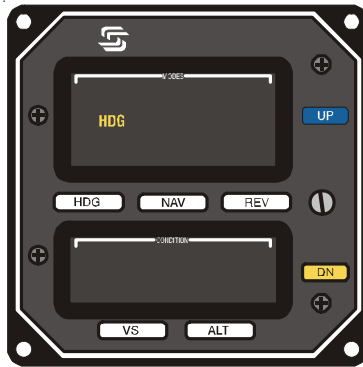

#### 3.2.2 Navigation (NAV)

The NAV mode provides roll commands for automatic intercept and tracking of selected VOR/LOC/RNAV/LORAN/GPS navigational signals.

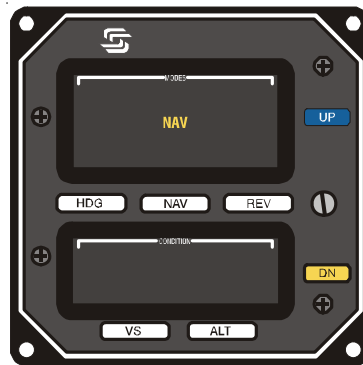

### 3.2.3 Reverse (REV)

REV mode provides roll commands for automatic intercept and tracking of the back course localizer inbound or the front course localizer outbound.

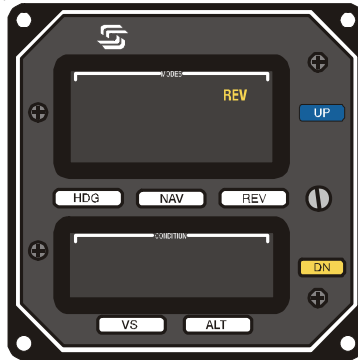

## 3.3 Pitch Modes of Operation

**NOTE:** Before engaging a pitch mode of operation, a roll mode must first be engaged.

### 3.3.1 Vertical Speed (VS)

The VS mode provides pitch synchronization of the autopilot to the aircraft vertical speed. To activate, press the VS mode switch. This activates the UP/DN (Down) pitch modifier switches for pilot commanded changes of vertical speed, up to a maximum of +/- 1600 feet per minute (rate of climb/descent).

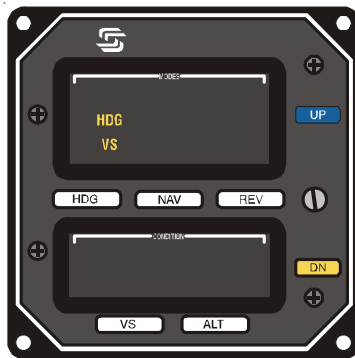

### 3.3.2 Altitude (ALT)

The ALT mode engages the altitude hold mode, capturing the altitude attained at the time of activation.

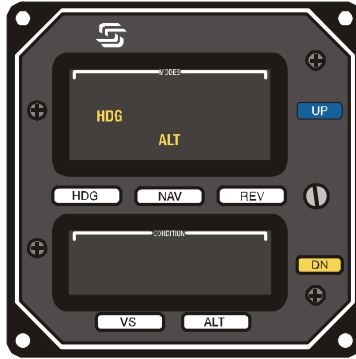

### 3.3.3 UP

When the VS mode is activated, the UP modifier switch will increase the rate-of-climb or decrease the rate-of-descent at 160 FPM for each second of continuous switch depression.

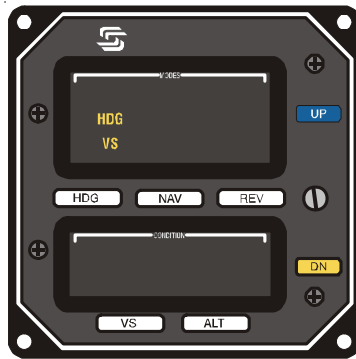

### 3.3.4 Down (DN)

When the VS mode is activated, the DN switch will increase the rate-of-descent or decrease the rate-of-climb 160 FPM for each second of continuous switch depression.

When the altitude hold mode is engaged, the UP and DN switches may be used to adjust the altitude. The UP and DN switches produce a 20 foot change in altitude for each second of depression, up to a maximum of 200 feet. Altitude changes of more than 200 feet require reactivation of the VS mode.

**NOTE:** For aircraft without auto trim, or where auto trim is disabled or turned off, the UP/DN switches are used to annunciate out of trim conditions when either the VS or ALT modes are engaged. If up trim is required, the UP switch will illuminate. If down trim is needed, the DN switch will illuminate. In both cases, the TRIM annunciation will also illuminate. The pilot should manually trim the aircraft in the direction indicated, until the light extinguishes. The aircraft will then be trimmed for existing flight conditions.

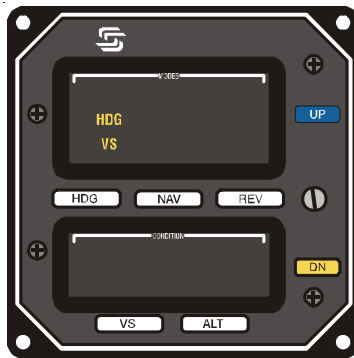

**NOTE:** There are four ways to disengage the autopilot (A/P):

1. Press the A/P disconnect/trim interrupt switch (normally mounted on the control wheel).
2. If pitch axis is engaged, operate the trim switch either way. (This will not disconnect the A/P if Autotrim is disabled or not installed).
3. Turn off the Autopilot Master Switch.
4. Locate and pull the autopilot circuit breaker.

Page Intentionally Blank

# **SECTION 4 PROCEDURES**

Page Intentionally Blank

## 4.0 Procedures

### 4.1 Pre-Flight Procedures

**NOTE:** To perform the system function check, adequate DC voltage must be supplied to the system, either 12 or 24 VDC, depending on the aircraft.

#### 4.1.1 Roll Axis

The following is a step by step procedure for preflighting the Roll Axis:

1. Place the A/P Master Switch to the **TEST** position. This should result in illumination of all annunciation's: **RDY, HDG, VS, FD, NAV, ALT, REV, APR, GS, SEL, UP, DN, FAIL, DSABL, TRIM, CAP,** and **SOFT**. After all annunciation's are observed, place the A/P Master Switch to the **ON** position. If the Turn Coordinator gyro is up to speed, only the **RDY** annunciation should remain on.
2. Rotate the heading knob on the Directional Gyro (DG) to position the bug under the lubber line.
3. Engage the HDG mode, and observe the **HDG** annunciation. Then move the DG heading knob left and right. The control wheel should move in the direction of bug travel. Return the bug to center.
4. Grasp the control wheel and manually turn it left and right to overpower the roll servo. There should be a noticeable increase in control wheel friction, no excessive looseness, no ratcheting or noise.
5. Turn on the NAV radio and tune a valid VOR signal. Then engage the NAV mode, observing the **NAV** annunciation. Move the VOR/OBS so that the needle swings left and right. The control wheel should move in the direction of needle travel. The **NAV** annunciation should flash when CDI deflection is over 50%.
6. Select REV mode, and observe the **REV** annunciation. Again, rotate the VOR/OBS knob. The control wheel should move opposite the direction of needle travel. The **NAV** annunciation should flash when CDI deflection is over 50%.
7. Channel a nonvalid VOR signal. The **NAV** annunciation should flash, and **FAIL** annunciation should illuminate (if the radio has a NAV flag output).
8. Disconnect by pressing and releasing the control wheel mounted A/P disconnect switch. Move the control wheel to ensure freedom of controls, and check to see that the **RDY** annunciator is flashing for approximately 5 seconds to indicate autopilot disconnect.

#### 4.1.2 Pitch/Altitude and Vertical Speed

The following is a step by step procedure for pre-flighting the Pitch/Altitude and Vertical Speed Systems:

1. Be sure the Autopilot Master Switch is **ON**, and that a roll axis mode has been selected.
2. Move the control wheel to level flight position and engage the VS mode. Press the UP modifier switch and hold. The control wheel should move aft, slowly. Press the DN switch and hold. The control wheel should move slowly forward.

**NOTE:** On some aircraft the autopilot may not be able to lift the elevators without pilot assistance during ground operation.

3. Overpower the pitch function by pulling the control wheel slowly aft. The TRIM annunciator and DN switch should illuminate and the audio warning should sound. Slowly push the control wheel forward. The TRIM annunciation and UP switch should illuminate and audio warning should sound. During overpower, there should be no excessive play in the controls or ratcheting noise.

#### 4. Pitch Limiter Test:

- A. Place the Master Switch to **TEST** position.
- B. Engage HDG mode.
- C. Engage ALT mode.
- D. Center and hold the control wheel, press and hold the UP switch. Pitch should disengage after about .5 seconds, release UP switch, pitch should reengage.
- E. Hold the control wheel, press and hold the DN switch. Pitch should disengage after about .5 seconds, release DN switch, pitch should reengage.

#### **CAUTION**

**If the pitch servo does not disengage when either the UP or DN modifier switch is engaged, the limit accelerometer may have failed. Do not use the autopilot pitch section until the problem is corrected. This check should be performed once per flight day. (Check FAA approved AFM supplement.)**

**NOTE:** If optional autotrim is not installed, this is the end of the preflight test. Press and release the disconnect switch on the control wheel, and place the Autopilot Master Switch in the OFF or ON position. Move aircraft controls to ensure freedom of movement and to make sure the autopilot has disconnected.

5. If the autopilot is equipped with optional autotrim, proceed with the following steps:

- A. Place Trim and Autopilot Master Switches to **ON**.
- B. Operate Manual Trim Switch (both segments) nose DN. Autopilot **TRIM** annunciator flashes and trim moves nose down (check manual trim wheel).
- C. Operate trim switch (both segments) UP, autopilot **TRIM** annunciator flashes, trim moves nose up (check manual trim wheel). Grasp aircraft trim control and overpower electric trim.
- D. Operate each segment of the trim switch separately. Trim should not operate unless both halves of the trim switch are operated simultaneously in the same direction.
- E. With trim operating, press trim interrupt switch. Trim motion should cease while interrupt switch is activated. Trim motion should resume when interrupt switch is released.

#### 4.1.3 Autotrim

1. Place autopilot and Trim Master Switches to **ON** and engage autopilot HDG and VS modes.
2. Grasp control wheel, slowly push forward. After approximately 3 seconds, trim should run nose up.
3. Slowly pull control wheel aft. After approximately 3 seconds, trim should move nose down.
4. Move manual trim switch up and down. Autopilot disengages, trim should operate in commanded direction (trim switch will disengage autopilot only when pitch is engaged).
5. Reengage HDG and VS modes and press trim interrupt/AP disconnect switch. Autopilot should disengage.
6. Trim aircraft for takeoff and check controls for freedom of movement. Be sure the autopilot and trim are disengaged.

#### **CAUTION**

**If either the manual electric trim or autotrim fails during any portion of the preflight, turn Trim Master Switch OFF. Do not use the electric trim until the fault is corrected. With Trim Master Switch OFF, the autopilot trim indicators and audio warning are reactivated. If the electric trim fails, or has an in-flight power failure, the system automatically reverts to indicator lights and audio warning. Should this occur, turn Trim Master Switch OFF, and revert to aircraft manual trim until the fault is corrected.**

## 4.2 NORMAL OPERATING PROCEDURES

**NOTE:** In order to activate any mode of the System 60-2 Autopilot, the Master Switch must be in the **ON** position and the **RDY** annunciator must be illuminated.

### 4.2.1 Roll Axis Modes

#### 4.2.1.1 Heading

1. Trim the aircraft for existing flight conditions.
2. Set the heading bug on the DG or optional HSI to the desired heading and press the HDG switch.

**NOTE:** The **HDG** annunciator will illuminate. A new heading can be selected by repositioning the heading bug. When operating in the HDG mode, the system is not coupled to any ground navigation device. It flies a specific heading, only. It will be necessary to monitor navigation instruments for course deviation due to wind drift, and to establish wind correction angles.



**Fig. 4-1. Directional Gyro**

#### 4.2.1.2 VOR Intercept and Tracking (DG)

1. To intercept and track a VOR signal, tune the navigation radio receiver to the proper frequency.
2. Select the desired VOR radial on the NAV indicator.
3. Move the heading bug in the direction of desired travel, to match the course of selected radial.
4. Engage the NAV mode.

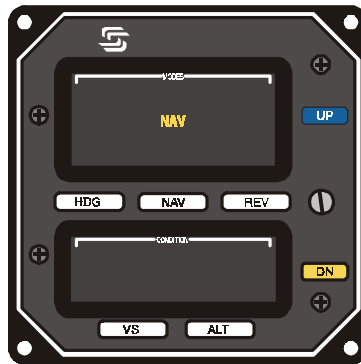

**NOTE:** If the VOR needle is at full-scale deviation, the autopilot will establish a  $45^\circ$  intercept angle to the desired course. As the aircraft approaches the selected radial, the autopilot senses the closure rate, and gradually, smoothly shallows the intercept angle. The point at which this turn begins is variable, depending on the aircraft position and closure rate to the radial. However, the turn will always begin between 100% (full-scale) needle deflection and 20% of full-scale. During the intercept sequence, the system operates in maximum gain and sensitivity to needle position and can command 90% of a standard rate turn.

When the selected course is intercepted and the needle is within 15% of centered, the **CAP** annunciator illuminates indicating course capture and initiation of the tracking gain sequence. This high sensitivity level is maintained for approximately 15 seconds while wind correction angle is established. Turn rate capability is then reduced to 45% standard turn rate (Capture/Soft Gain) identified by both the **CAP** and **SOFT** annunciator's.

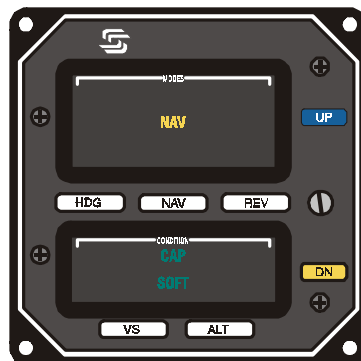

Approximately 45 seconds later, the maximum turn rate is reduced to 15% of standard rate (Soft Gain), and the lowest level of sensitivity is achieved, identified by the **NAV** and **SOFT** annunciation's. The **CAP** annunciation extinguishes. This condition provides low activity levels during station passage when VOR signals are erratic.

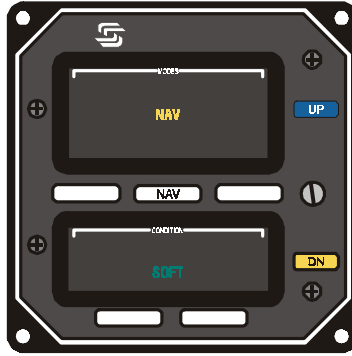

The system also includes a course deviation monitor. If the aircraft strays off course or LOC centerline by 50% needle deflection, the **NAV** annunciator flashes as a warning. It should flash at station passage because of short-term needle excursion beyond 50%. It also flashes when the NAV flag is in view. When that occurs, the **FAIL** annunciation will illuminate.

**NOTE:** When operating in the NAV/ SOFT mode, and needle deflection of 50% or more is experienced for 1½ minutes, the gain program will switch to NAV/CAP/SOFT, increasing sensitivity and authority to reestablish the aircraft on course. When a course change of 10° or more is required at an enroute waypoint, select the new course, and reset the NAV mode to reinstate the capture sequence. Set the DG heading bug to the new course.

4.2.1.3 VOR Approach (DG)



**Fig. 4-2. VOR/LOC/GPS**

During a VOR approach, it is recommended that the NAV mode switch be depressed just after TO/FROM reversal after the needle has stabilized at the Final Approach Fix inbound.

This returns the system to capture dynamics and reinstates the high sensitivity gain scheduling.

#### 4.2.1.4 Localizer Intercept and Tracking (DG)



When a localizer frequency is channeled, and NAV mode is selected, the system will automatically execute high sensitivity gain for the approach and automatically activates the APR mode. The **APR** annunciator illuminates.

Set the heading bug to the inbound localizer course, and engage the NAV mode to intercept and track the localizer front course inbound or back course outbound.

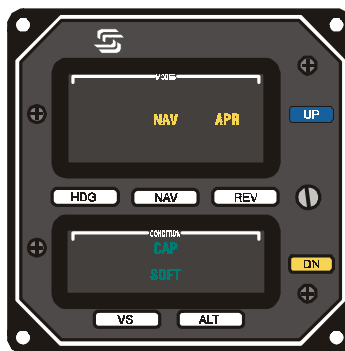

## Straight-in Localizer Approach and Tracking (DG)

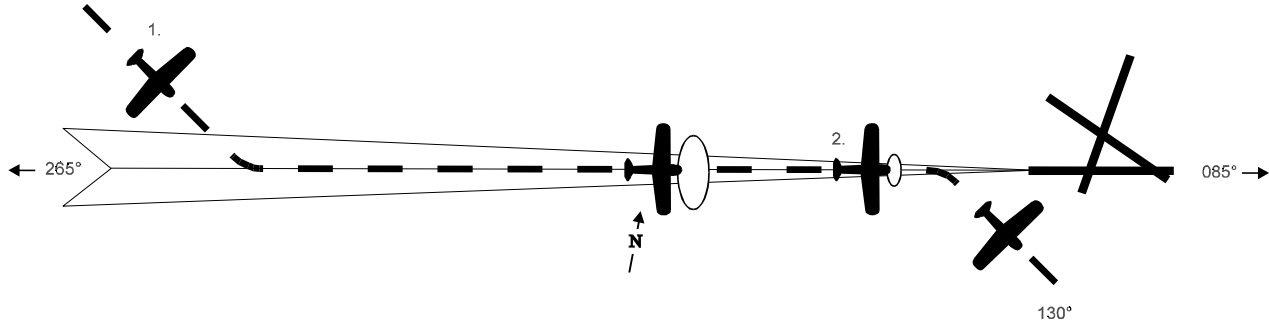

1.
  - a. Tune navigation radio to localizer frequency.
  - b. Set **HDG** bug to published **inbound** course.
  - c. Press **NAV** mode switch. Autopilot will intercept, capture and track the localizer course.
2. If a missed approach is declared at the middle marker:
  - a. Disconnect the autopilot and stabilize the aircraft for the missed approach climb.
  - b. Set the **HDG** bug to the published missed approach heading.
  - c. Press the **HDG** mode switch.
  - d. Press the **VS** mode switch if desired.

*Fig. 4-3*

## Procedure Turn Localizer Approach and Tracking (DG)

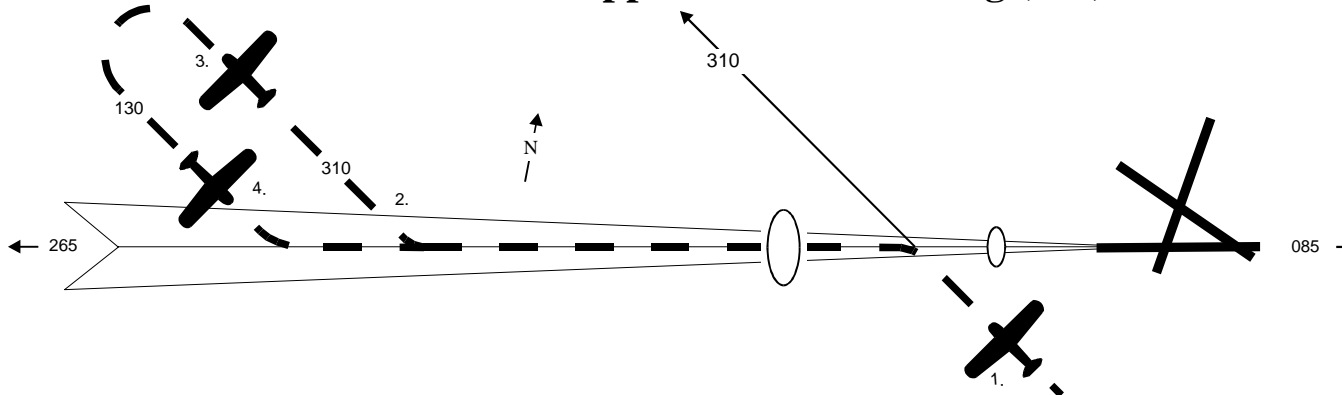

1.
  - a. Tune navigation radio to LOC frequency.
  - b. Set heading bug to published outbound LOC heading.
  - c. Push **REV** mode switch.
2.
  - a. Set heading bug to outbound procedure turn heading.
  - b. Press **HDG** mode switch.
3. In 90 increments, set heading bug to *inbound* procedure turn heading.
4.
  - a. Set heading bug to inbound LOC heading.
  - b. Press **NAV** mode switch. Autopilot will intercept, track, and capture localizer course inbound to the airport.

**Fig. 4-4**

## Back Course Straight-In Approach (DG)

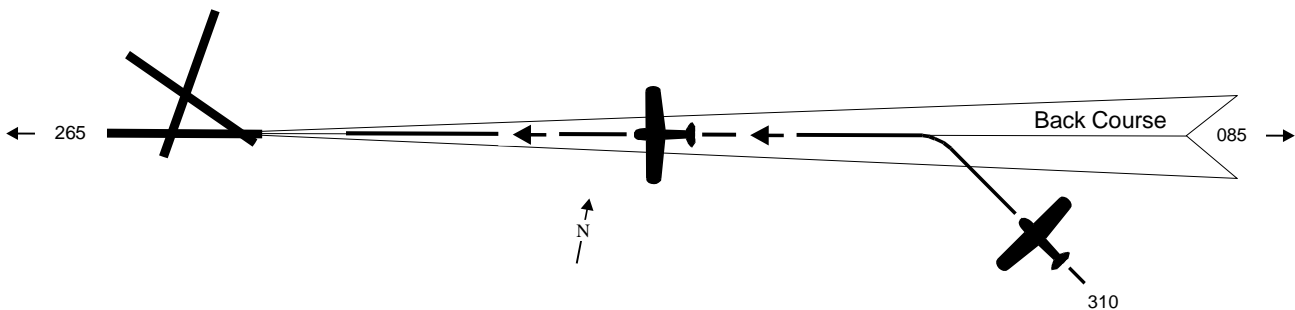

1.
  - a. Tune navigation radio to LOC frequency.
  - b. Set heading bug to the back course inbound final approach heading.
  - c. Press **REV** mode switch. Autopilot will intercept and track the back course to the airport.

*Fig. 4-5*

## Back Course Procedure Turn (DG)

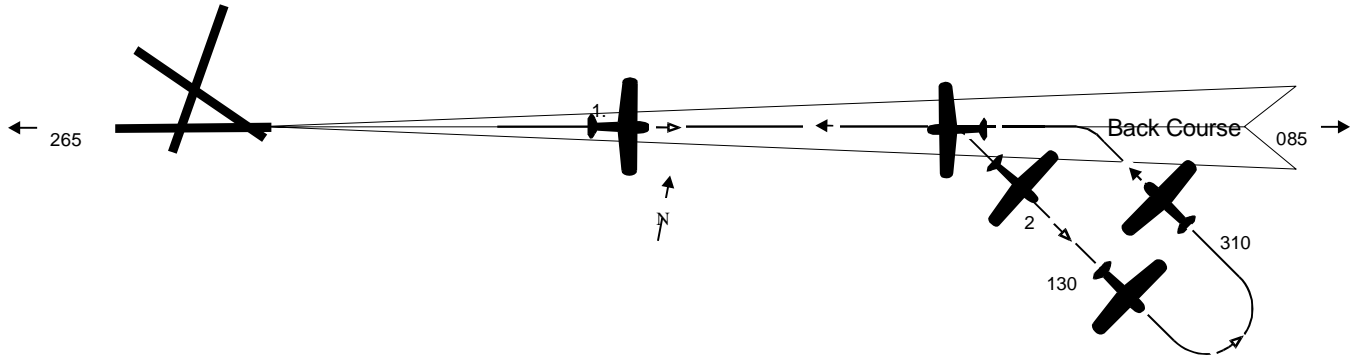

1.
  - a. Tune navigation receiver to LOC frequency.
  - b. Set heading bug to published inbound front course heading.
  - c. Press **NAV** mode switch.
2.
  - a. Set heading bug to outbound procedure turn heading.
  - b. Press **HDG** mode switch.
3. In 90° increments, set heading bug to inbound procedure turn heading.
4.
  - a. Set heading bug to published final approach course heading.
  - b. Press **REV** mode switch. Autopilot will complete intercept, capture and tracking of localizer back course, inbound.

*Fig. 4-6*

4.2.1.5 VOR/Localizer Intercept and Track (HSI Option)



**Fig. 4-7. Horizontal Situation Indicator**

If your aircraft is equipped with an optional HSI, the autopilot will receive both VOR left/right information and course information. With an HSI, the heading bug is not used during radio tracking. To make a VOR or Localizer approach, tune the navigation receiver to the required frequency. Set the desired VOR radial or Localizer course with the course selector. Press and release the NAV mode switch.

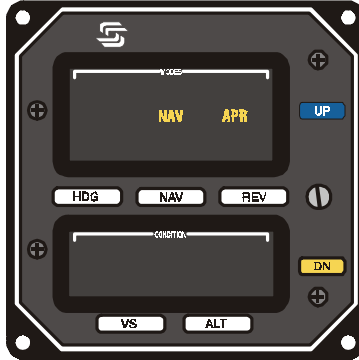

**NOTE:** Localizer approaches with an HSI require that the inbound front course be set on the course selector for either front course or back course operations. To track inbound on the front course, activate the NAV mode. NAV mode also is used for tracking outbound on the back course.

To fly the back course, activate the REV mode. It is used to track inbound on the back course, and outbound on the front course. The course selector must be set to the inbound front course.

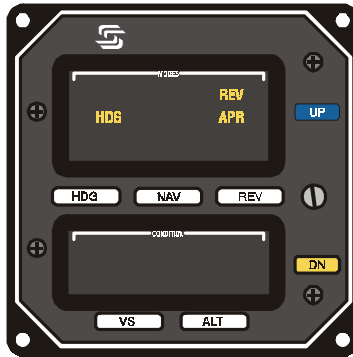

#### 4.2.1.6 Dual Mode Intercept

**NOTE:** During operations with an HSI, simultaneous activation of both the HDG and NAV modes will provide selected angle intercepts. In flying a radial or localizer intercept, the autopilot will follow the heading bug until the aircraft reaches the proper on course turn point. It will then switch from HDG to NAV mode automatically. Selected angle intercepts may be used during VOR, localizer front course and back course (REV) operations.

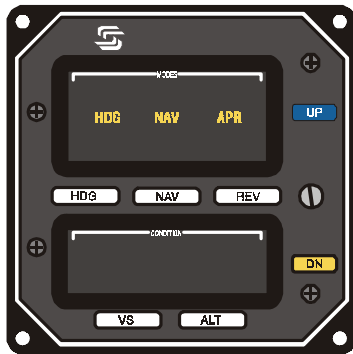

Localizer intercept angles greater than 45° usually result in some course overshoot, depending on the distance from the station and speed of the aircraft. Therefore, angles greater than 45° are not recommended.

## Straight-in Localizer Approach and Tracking (Optional HSI)

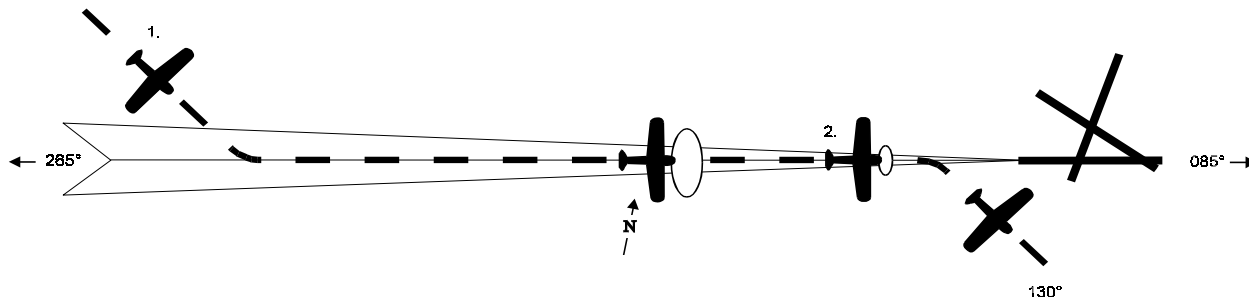

1.
  - a. Tune navigation radio to **LOC** frequency.
  - b. Set course pointer to published **inbound LOC** course heading.
  - c. Press **NAV** mode switch. Autopilot will intercept, capture, and track the localizer.
2.
  - a. Once **NAV** mode is established, heading bug can be set to published missed approach heading.
  - b. At the middle marker, if a missed approach is declared, disconnect the autopilot and stabilize the aircraft for the missed approach climb before engaging **HDG** mode.

**NOTE:** To establish a pilot selectable angle of intercept (dual mode intercept), set the course pointer to the published inbound front course heading, and the heading bug to the desired heading to establish the selected angle intercept or to the **Radar Vector HDG**. Press the **HDG** and **NAV** mode switches simultaneously. Upon capture of course, the autopilot automatically cancels **HDG** mode and tracks the final approach course. Heading bug can be set to missed approach heading after course capture.

*Fig. 4-8*

## Procedure Turn Localizer Approach and Tracking (Optional HSI)

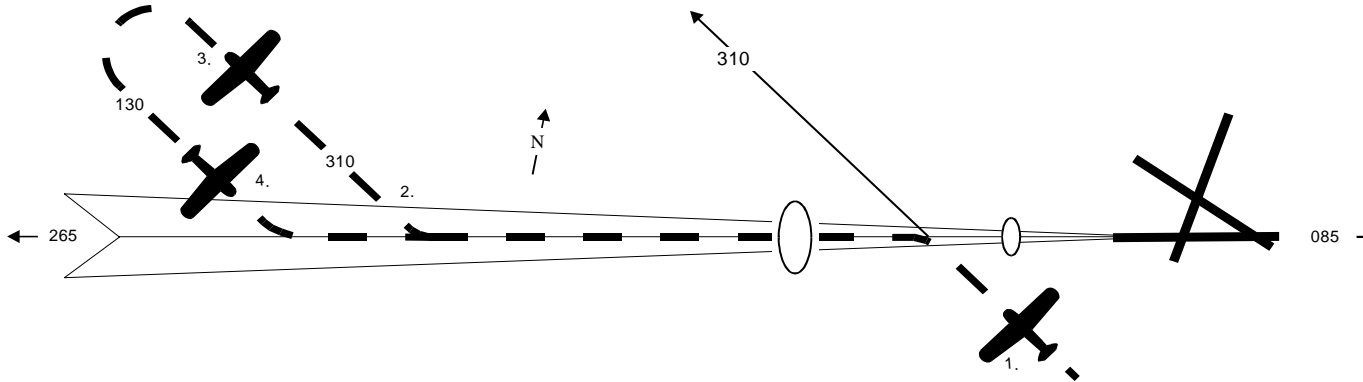

1.
  - a. Tune navigation radio to LOC frequency.
  - b. Set published inbound LOC course heading with course pointer.
  - c. Push **REV** mode switch.
2.
  - a. Set heading bug to published outbound procedure turn heading.
  - b. Press **HDG** mode switch.
3.
  - a. In 90° increments, set heading bug to inbound procedure turn heading.
  - b. When established on inbound procedure turn heading, press **NAV** mode switch. Autopilot will intercept, track, and capture the localizer.
4. Once established in **NAV/APR** mode, the heading bug can be set to the published missed approach heading.

*Fig. 4-9*

## Back Course Straight-In Approach (Optional HSI)

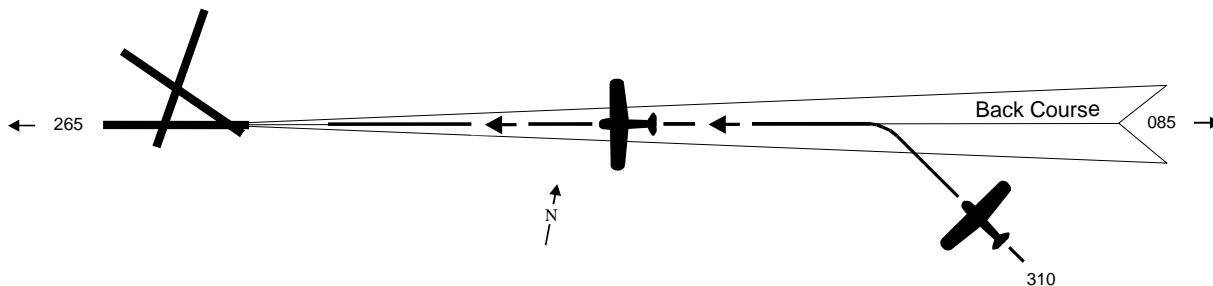

1.
  - a. Tune navigation radio to LOC frequency.
  - b. Set HSI Course Pointer to published **inbound front course heading**.
  - c. Press REV mode switch. Autopilot will intercept, capture, and track Localizer back course to the airport.

**NOTE:** To establish a pilot selectable angle of intercept (dual mode intercept), on the back course, set the course pointer to the published inbound front course heading, and the heading bug to the desired heading to establish the selected angle intercept or to the Radar Vector HDG. Press the HDG and REV mode switches simultaneously. Upon capture of the back course, the autopilot automatically cancels HDG mode and tracks the final approach course. The heading bug can be set to the missed approach heading after course capture.

*Fig. 4-10*

## Back Course Procedure Turn (Optional HSI)

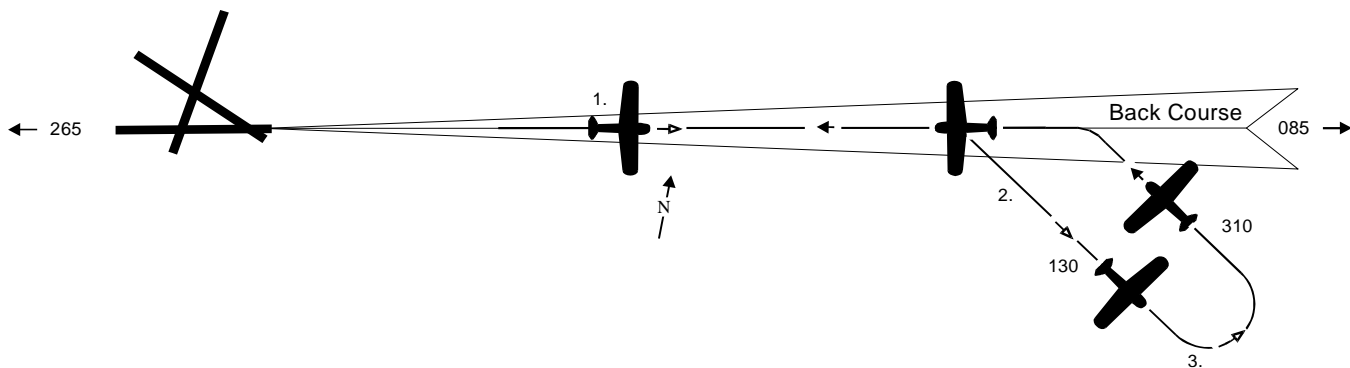

**REVERSE** mode is used to track the front course outbound or the back course inbound to the airport. The HSI Course Pointer **MUST** be set to the front course inbound heading.

1.
  - a. Tune the navigation receiver to the LOC frequency.
  - b. Set the course pointer to the published inbound LOC front course heading.
  - c. Press the NAV mode switch. The autopilot will track the back course outbound.
2.
  - a. Set the heading bug to the published outbound procedure turn heading.
  - b. Press the HDG mode switch.
3.
  - a. In 90° increments, set the heading bug to the inbound procedure turn heading.
  - b. Position the aircraft on the localizer Back Course with the HDG bug.
  - c. Press REV mode switch. The autopilot will track the back course inbound to the airport.

*Fig. 4-11*

## 4.2.2 Pitch Axis Modes

**NOTE:** A Roll Mode must be selected before selecting a Pitch Mode.

### 4.2.2.1 Vertical Speed (VS)

When establishing an automatic climb out to a desired altitude (without optional ALT Selector Alerter), press and release the **VS** mode switch to engage the vertical speed mode. The autopilot automatically synchronizes to the established rate-of-climb or descent. If the established rate-of-climb exceeds 1600 FPM, at VS engagement, the autopilot will seek to maintain 1600 FPM. Should a specific rate-of-climb/descent be required, press the appropriate UP/DN modifier switch. For each second of depression (UP or DN), there is a 160 FPM change of vertical speed. For example, to establish a 500 FPM rate-of-climb, press and hold the UP modifier switch for approximately 3 seconds to transition from level flight to a 500 FPM climb. To descend at approximately 500 FPM, press the DN switch for approximately 3 seconds.

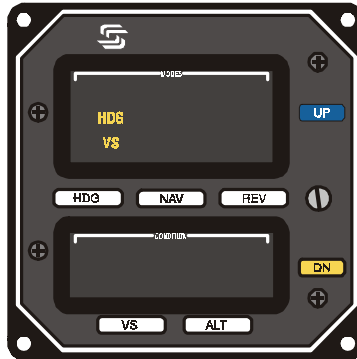

**NOTE:** If the VS mode annunciator flashes, it indicates an excessive error between the actual VS compared to the selected VS. The pilot should adjust the aircraft power or correct the VS that has been selected.

#### CAUTION

**Vertical speed change is time related: 160 FPM for each second of switch depression. Autopilot response to a commanded VS change is precise. DO NOT continue to depress modifier switches beyond the time required to program the desired vertical speed change. In other words, until the attitude change "looks right". The autopilot will change attitude very slowly in the direction of the command.**

**Operation of the optional Altitude/Vertical Speed Selector is contained in a separate manual.**

#### 4.2.2.2 Altitude Hold (ALT)

Upon reaching the desired or assigned altitude, press and release the ALT switch. The altitude hold mode will engage at the altitude reached at the time of engagement. There is typically no need to "lead" the desired altitude. If there is a difference between the altitude engagement point and the altimeter, use the appropriate UP/DN modifier switch to make the necessary altitude correction.

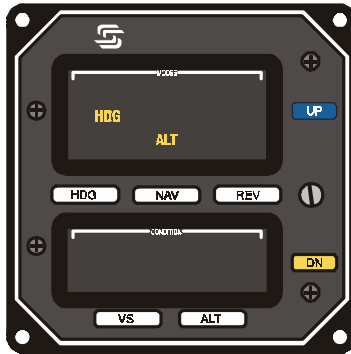

**NOTE:** While in the altitude mode, 1 second of modifier switch depression will change the altitude approximately 20 ft., up to a maximum of 200 feet.

**NOTE:** If more than 200 feet of altitude correction is necessary, reengage the VS mode, fly to the desired altitude, and reengage the ALT mode.

#### 4.2.2.3 Intercepting and Coupling the Glideslope

To arm the automatic glideslope (GS) capture function, the following conditions must be met:

1. NAV receiver must be tuned to the appropriate frequency.
2. The glideslope signal must be valid; no flag.
3. The autopilot must be in NAV/APR/ ALT modes.
4. The aircraft must be 60% or more below the GS centerline during the approach to the intercept point, and within 50% needle deviation of the localizer centerline at the point of intercept, usually the outer marker.

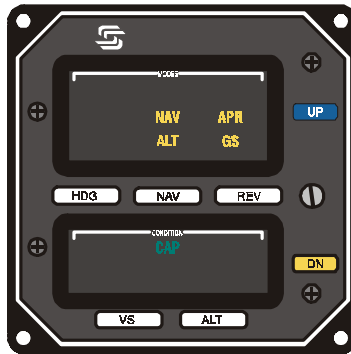

**NOTE:** GS arming will occur when the above conditions have existed for 10 seconds. Illumination of the **GS** annunciator will occur, indicating arming has been accomplished. The **ALT** annunciator remains on. GS capture is indicated by extinguishing of the **ALT** annunciation at GS intercept.

#### 4.2.2.4 Manual Arm/Automatic Capture

If approach vectoring locates the aircraft above or too near the GS centerline at the intercept point, usually the outer marker, it becomes necessary to execute a manual arming of the GS. This is done by:

1. Pressing the ALT switch once if operating in the altitude hold mode.
2. Pressing the ALT switch twice if operating in the VS mode. Once capture is achieved, the **GS** annunciation will illuminate, and the **ALT** annunciation will extinguish.

**NOTE:** If it becomes necessary to establish a holding pattern at the outer marker, automatic glideslope arming can be disabled by pressing the NAV switch a second time while in the NAV/APR mode. The **GS** annunciator will flash, and the Disable (**DSBL**) annunciator will illuminate, to indicate that the GS mode is disabled. To reestablish GS arming, press the NAV mode switch again. The **DSBL** condition annunciator will extinguish, the **GS** annunciator will cease to flash.

## Glideslope Intercept and Track

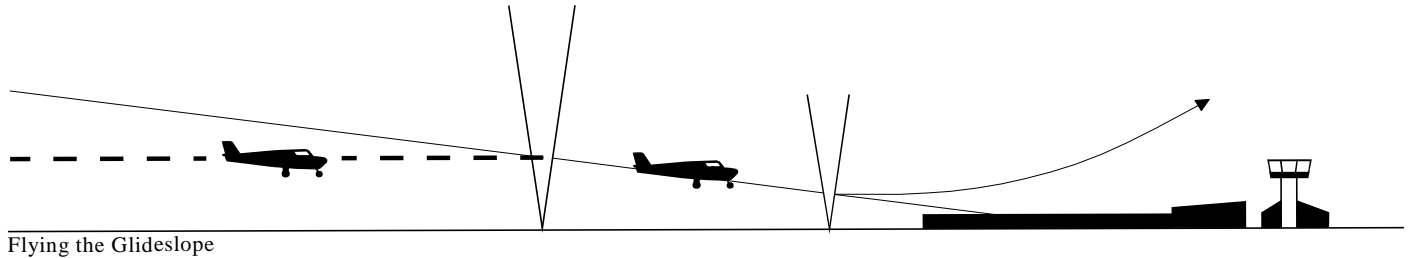

**NOTE:** When making an ILS approach, be sure to follow the published procedure for the approach you have been cleared to make. (See text for Localizer Intercept and Tracking.)

1. Approach the glideslope intercept point with the aircraft stabilized in the Altitude Hold (ALT) mode.
2. If the aircraft requires approach flaps, lower the flaps to the proper position. (refer to FAA/AFM supplement for flap use limitations.)
3. At glideslope intercept, lower the landing gear (if applicable) and adjust power for the desired descent speed and published rate of descent. For best tracking results, make small power adjustments to maintain the desired rate of descent and airspeed.
4. At the decision height, or the autopilot's minimum operating altitude, whichever is higher, disengage the autopilot to execute a manual landing, or a go around maneuver. If a missed approach is declared, the autopilot can be re-engaged after a stabilized climb has been established.

*Fig. 4-12*

## Procedure Turn for Glideslope Approach

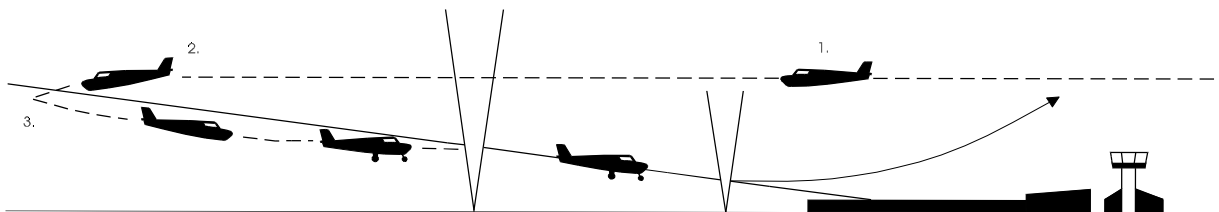

1.
  - a. Tune navigation radio to ILS frequency.
  - b. Follow the procedure(s) for LOC Approach Intercept and Tracking in this manual.
2.
  - a. If a procedure turn is required, enter the procedure turn at the published procedure turn altitude or descend to it.
  - b. At the procedure turn altitude, press the VS mode switch.
  - c. Inbound to the Final Approach Fix (FAF) engage ALT mode, if not already in altitude hold.
  - d. When the NAV mode switch is pressed, and if the aircraft is below the glideslope, the APR and GS annunciators will illuminate.
3.
  - a. Upon capture of LOC course, NAV, APR, ALT and GS will illuminate if all conditions for glideslope operation are met (see text, ref. Glideslope Operation). This signifies automatic arming of the Glideslope function.
  - b. Upon Glideslope capture, the ALT annunciation will extinguish, signifying GS capture.

**NOTE:** If the final approach flown locates the aircraft above the glideslope prior to reaching the outer marker, follow the procedure outlined in the text for Manual Arming of the Glideslope.

*Fig. 4-13*

**NOTE:** To fly a holding pattern, if inbound to the outer marker while in NAV mode, press the NAV switch a second time to disable the GS arming. When the outer marker is reached, press and release the HDG switch, and rotate the heading bug in the direction of the turn. It is best to select the reciprocal course in increments of 90°, rather than the full 180°. When the outbound leg is completed, rotate the HDG bug in the direction of the turn, in 90° increments, to reestablish the inbound course, and press and release the NAV switch twice. On the inbound leg, when ready to complete the approach, rearm the GS function by pressing and releasing the NAV switch once again. Rearming will occur when all other required functions have been met.

#### 4.2.2.5 Elevator Trim Indicator

The autopilot pitch servo contains a sensor for detection of elevator out-of-trim loads. Without optional Autotrim, when such forces exceed a preset level, the **TRIM** annunciator will illuminate, and either the **UP** or **DN** annunciator will light up, indicating the direction of required trim. Annunciation will be steady for about 5 seconds, then will flash until proper trim conditions have been met.

**NOTE:** If the **TRIM** annunciation is illuminated and the autopilot is disengaged, there will be a residual out-of-trim force at the control wheel. Be alert for this condition if the autopilot is disengaged while the **TRIM** lights are on.

#### 4.2.2.6 Optional Autotrim

If the autopilot is equipped with optional Autotrim, the aircraft elevator trim will be maintained automatically when the Trim Master Switch is ON and a pitch mode is activated.

When the Trim Master Switch is ON, the trim annunciators are disabled. If the switch is OFF, or a power failure occurs, the annunciators automatically become functional.

The trim system is designed to accept any type of single failure, mechanical or electrical, without uncontrolled operation resulting. To ensure that no hidden failures have occurred, conduct a trim preflight check prior to every flight. (Consult the appropriate AFMS or POH.)

### 4.3 Flight Director Operations (Optional)

#### 4.3.1 Single Cue

This system, which integrates both the roll axis, and pitch axis, offers synchronized display of the flight profile. It is automatically activated when the autopilot pitch axis is engaged. A Flight Director provides a visual indication of how accurately the pilot or autopilot is tracking the commands of the active mode of operation.

Activation is indicated by illumination of the **FD** annunciator. A remote parallax adjustment is provided to change the height of the horizontal display to compensate for different seat heights. And a remote switch allows manual flight control via Flight Director commands.

For proper flight technique, the system presentation requires the pilot to roll and pitch the aircraft toward the display until the delta shaped reference is tucked into the steering command bars, indicating that commands have been satisfied. For example, if the display is up and left, the pilot would be required to establish a left turn, pitch up attitude. As bank angle and vertical speed approach the required amounts, bank angle and pitch up attitude are shallowed. When the delta reference and the steering bars are matched, the commands have been met. Thereafter, it is necessary to maneuver the aircraft to keep the display elements matched in order to accurately fly the selected modes.

Accurate flight director operation requires alertness by the pilot and monitoring the movement of the display. Keeping it matched is quite simple. However, control inputs must be timely and smooth for accurate flight director following of the desired command.

For manually controlled flight by the flight director, place the FD master switch in the ON position, and the autopilot master switch in the OFF position. This disables the autopilot servos, allowing the pilot to control the aircraft to flight director commands. To return to autopilot flight simply move the AP switch to "ON".

### 4.3.2 Two Cue

This system, also known as an Attitude Director Indicator (ADI), is automatically activated when the autopilot is engaged. Activation is indicated by illumination of the **FD** annunciator.

This system contains a vertical steering bar for roll commands, and a horizontal steering bar for pitch commands. It also includes an FD flag which is displayed when the roll steering bar is not active. This system allows split axis operation so flight in roll axis by itself is available. The horizontal pitch steering bar is biased out of view when the AP Master Switch is on, until a pitch mode is activated. A remote parallax adjustment is provided to change the height of the pitch steering bar for different seat heights. A remote switch allows manual flight control via Flight Director commands.

Proper flight director technique for a Two Cue steering presentation requires the pilot to roll and pitch the aircraft toward the steering bars until they are centered, indicating that commands have been met.

For example, if the vertical (roll) bar is left, and the horizontal (pitch) bar is up, the aircraft is below the desired attitude, or horizon, and right of desired course, or centerline. A left bank and a pitch up attitude is dictated. As bank angle and vertical speed approach desired values, the bars will move to the center, or "crossed-hair" position. At this point, commands have been satisfied. Thereafter, it is necessary only to maneuver the aircraft to keep the bars centered in order to accurately fly programmed modes.

It should be noted that accurate Flight Director operation demands that the pilot stay alert to the movement of the steering bars, and to maneuver the aircraft in a timely and smooth manner to satisfy the bar commands.

Proper use of a Flight Director System makes flying much more precise and less burdensome because of the computed display.

### 4.4 Yaw Damper/Rudder Trim System (Optional)

The S-TEC accelerometer controlled yaw damper/rudder trim system substantially improves autopilot performance, as it senses both yaw and slip in a single sensor. It also contains a trim potentiometer that allows centering of the turn and slip ball. It replaces the commonly used rate gyro with a sensitive accelerometer. The S-TEC system offers two modes of operation:

1. Auto, which automatically activates when the autopilot is engaged.
2. ON, which permits operation whether or not the autopilot is in use.

It also provides a three position switch, which lets the pilot select AUTO, ON, or Off positions.

Page Intentionally Blank

# **SECTION 5 APPENDIXES**

**Table of Contents**

**Appendix A:** System Failure and Caution Annunciations.....5-3  
Roll Axis.....5-3  
Pitch Axis.....5-4

**Appendix B:** Specifications.....5-5

## Appendix A

### System Failure and Caution Annunciations

#### Roll Axis

<u><b>ANNUNCIATION</b></u>	<u><b>CONDITION</b></u>	<u><b>ACTION</b></u>
Flashing <b>RDY</b> for 5 seconds.	Indicates autopilot disconnect. All annunciations except <b>RDY</b> are cleared.	N/A
Flashing <b>RDY</b> , then extinguish.	Turn coordinator gyro rotor speed low. Auto pilot disconnects, cannot be reengaged.	Check instrument power; A/P not ready may indicate a TC problem. Investigate before IFR flight
Flashing <b>NAV</b> or <b>REV</b> .	Indicates off Course by 50% needle deflection.	Use HDG mode until problem is identified. Cross check raw NAV data, compass HDG, and radio operation.
Flashing <b>NAV</b> or <b>REV</b> , steady <b>FAIL</b> mode.	Indicates invalid radio navigational signal.	Check navigation radio. Use HDG until problem is corrected.

**NOTE:** If any of the above annunciations's occur at low altitude or during an actual instrument approach, disengage the autopilot, execute a missed approach, and inform Air Traffic Control (ATC) of the problem. Do not attempt to troubleshoot or otherwise determine the nature of the failure until a safe altitude and maneuvering area are reached. The NAV flag failure annunciation depends upon the availability of radio flag outputs and radio type.

## Appendix A

### System Failure and Caution Annunciations

#### Pitch Axis

<u><b>ANNUNCIATION</b></u>	<u><b>CONDITIONS</b></u>	<u><b>ACTION</b></u>
Flashing <b>GS</b>	Indicates off glideslope centerline by 50% or more.	Check attitude and power. Add or reduce power as appropriate.
Flashing <b>GS</b> with steady <b>FAIL</b>	Indicates nonvalid glideslope radio navigation signal.	Disconnect A/P, initiate missed approach, inform ATC.
Flashing <b>VS</b>	Indicates excessive vertical speed error over selected VS (usually in climb).	Reduce command VS and/or adjust power.
Flashing <b>GS</b> , steady <b>DSBL</b>	Indicates manual glideslope disable.	To reenable, reset NAV switch.

**NOTE:** If any of the above annunciations occur at low altitude or during an actual instrument approach, disengage the autopilot and execute a missed approach. Inform ATC of the problem. Do not attempt to troubleshoot or otherwise identify the nature of the failure until a safe altitude and maneuvering area are reached.

## Appendix B

### Specifications

#### Programmer

Power required	14/28 VDC
Weight	1.9 lbs
Dimensions	3.3 x 3.3 x 5.2 in.

#### Turn Coordinator

Power required	14/28 VDC
Flag voltage detector operating limits	9 VDC (Approx.)
Flag RPM detector operating limits	Nominal less 20%
Current requirements	.8 amp
Weight	1.8 lbs.
Dimensions	3.275 x 3.275 x 5.62 in.

#### Roll Computer

Power required	14/28 VDC
Weight	2.3 lbs.
Dimensions	5.25 x 2.1 x 13.3 in.

#### Pitch Computer

Power required	14/28 VDC
Weight	3.0 lbs.
Dimensions	5.25 x 2.1 x 13.3 in.

**NOTE:** Unit will operate with either 14 or 28 VDC. However, servo amplifier circuit board must be set up for specific voltage.

**Appendix B**

**Specifications  
(Cont'd)**

**Roll Servo**

Power required	14/28 VDC
Current	Included in system value power required.
Weight	2.9 lbs.
Dimensions	7.25 x 3.75 in.

**Pitch Servo/Trim Sensor**

Power required	14/28 VDC
Current	Included in system value power required.
Weight	2.9 lbs.
Dimensions	7.25 x 3.75 in.

**Altitude Pressure Transducer**

Power required (supplied by pitch computer)	10 VDC
Pressure range	0-15 PSI Absolute
Overpressure	150% operating maximum

**System Current Requirement**

Average operating current	1.0 amp
Maximum current	5.0 amp

# **SECTION 6 GLOSSARY**

Page Intentionally Blank

**GLOSSARY**

<b>Term</b>	<b>Meaning</b>
AFM/(S)	Airplane Flight Manual/ (Supplement)
ALT	Altitude
APR	Approach
A/P	Autopilot
ATC	Air Traffic Control
CAP	Capture
CDI	Course Deviation Indicator
DC	Direct Current
DG	Directional Gyro
DN	Down
DSBL	Disable
FAA	Federal Aviation Administration
FD	Flight Director
FPM	Feet Per Minute
GPS	Global Positioning System
GS	Glideslope
HDG	Heading
HSI	Horizontal Situation Indicator
IFR	Instrument Flight Rules
IN.	Inches
LBS	Pounds
LOC	Localizer
LORAN	Long Range Navigation
N/A	Not Applicable
NAV	Navigation
REV	Reverse
OBS	Omnibearing Selector
POH/(S)	Pilot Operating Handbook/ (Supplement)
PSI	Pounds Per Square Inch
RDY	Ready
REV	Reverse
RPM	Revolutions Per Minute
SFM	Supplemental Flight Manual
TC	Turn Coordinator
VDC	Volts Direct Current
VMC	Visual Meteorological Conditions
VOR	Very High Frequency Omnidirectional Radio Range
VS	Vertical Speed
YD	Yaw Damper

Page Intentionally Blank

# S-TEC

One S-TEC Way · Municipal Airport  
Mineral Wells, Texas 76067-9236 USA  
Telephone: 940/325-9406; FAX: 940/325-3904  
1-800-USA-STECH  
[www.s-tec.com](http://www.s-tec.com)

Information in this document is subject to change without notice.  
©1999 S-TEC . All rights reserved. Printed in the United States  
of America. S-TEC and the S-TEC logo are registered  
trademarks of S-TEC.

**Notice: You must contact S-TEC Customer Support at 800-872-7832  
for a Return Material Authorization (RMA) number prior to the  
return of any component for any reason.**

P/N: 8783  
Date: 01 November 2001  
Printed in USA